

Volume: “Approaches to language and cognition”, edited by Heli Tissari, in: [Studies in Variation, Contacts and Change in English](#), Helsinki (forthcoming 2008).

Wolfgang Wildgen

The “dynamic turn” in cognitive linguistics

Abstract:

The introductory sections of this paper ask the following basic questions about the proper goals of linguistic theory: Why did linguistic structuralism fail as an explanatory endeavour? Why is the understanding of the dynamics of language a primordial goal of linguistic theory? In order to give an explanation of the notion “dynamics” basic notions of dynamic systems theory are introduced informally. Following these questions the paper considers major proposals by Talmy, Lakoff and Langacker and asks how they account for the dynamic aspects of causing/enabling (Talmy’s force dynamics), for iterated metaphorical mapping (Lakoff) and for syntactic composition (“construal” in Langacker’s terminology). The ad-hoc pictorial models proposed by these authors are compared to mathematically controlled models in dynamic semantics (based on catastrophe, bifurcation and chaos theory). Shortcomings and advantages of the informal and pictorial versus the mathematical description are discussed. The dynamics of phrasal and sentential composition is currently one of the central topics of neurodynamic models based on ERP and fMRI brain scanning. This perspective must be further developed in order to specify the possibilities of future dynamic semantics of natural languages.¹

1 Why did linguistic structuralism fail as an explanatory endeavour?

Cognitive linguistics has inherited basic orientations and delimitations from structuralism as it was programmatically stated by de Saussure and Hjelmslev. This dependence is obscured by the fact that both the Chomsky and the Langacker/Lakoff line seem to descend from later “revolutions”. The Chomsky revolution against the classificatory and taxonomic trends in postwar American linguistics (Harris, Pike) programmatically introduced creativity, generativity and transformation into the static world of the patterns of usage uncovered by descriptive techniques (discovery procedures and classification based on distributions). In reality, the rather informal nature of discovery procedures and classificatory methods has been

¹ I acknowledge relevant comments made by Prof. Heli Tissari. Made of them led to changes in the current version.
Dynamicturn2008korr2.doc

replaced by a much more rigid algebraic formalism. For Chomsky (1957) language was considered as a non-finite, but denumerable set, which could be defined via an algorithm, whereas his teacher Harris rather had tried to give a mathematical shape to the methods of linguistic research. The major arguments for the necessity of Chomsky's rigor derived from Bar-Hillel's (1950) proof that a distributional (purely algebraic) definition of classical notions like word classes was not feasible.² One could say that by a strange parallel fate the formalization of Saussure's structuralisms by Hjelmslev was repeated by Chomsky/Bar-Hillel vis à vis American structuralism (in the tradition of Bloomfield, Bloch, Trager, Pike). Lakoff's and Fillmore's second "revolution" turned against the formal language analogy, but it also returned to post-Saussurean developments like those in the German "inhaltsbezogene Grammatik" of Leo Weisgerber and to a Whorfian view on language and cognition (Weisgerber had preferred to label it "Humboldtian"). All these turns and revolutions did not really abolish the Saussurean verdict against historical dynamics and against the consideration of language to be dependent from variations in social contexts and individual ontogenesis. The rejection of evolutionary considerations had already been banished by pre-Saussurean verdicts in Europe after 1850.³

For many historians of linguistics this development seemed to be the necessary condition for the advance of linguistics and the formation of a modern scientific discipline. If we look at the major sciences and their development after 1850 a strange contradiction appears. The basic question of how to deal with dynamics in physics (later in chemistry) made revolutionary advances beyond Newtonian dynamics, mainly with the further advance in the mathematics of differential calculus, non-Euclidean geometries, topology, and differential topology (Felix Klein, Henri Poincaré are perhaps the best known mathematicians who contributed to these advances). In physics the wave and fields dynamics of Maxwell, quantum dynamics and Einstein's relativity theories stand for the breakthrough of the dynamical view in the sciences. Applications in chemistry, biology and psychology later followed this trend. Strangely enough, linguistic structuralism to the contrary banished the dynamics of language in its struggle for scientific recognition. Logics and algebraic algorithms became the implicit ideals of a fully emancipated science of language.

² Both of them dismissed inductive, statistically based classifications, which are currently continued in corpus linguistics.

³ The aspects of structuralism become obvious if we compare the Saussurean position to that of the American classic W.D. Whitney: *The life and growth of language* (1899).

Our position in this paper is clearly that this movement, which has dominated most theoretical thinking in linguistics during the 20th century, was a garden path: In order to explain human language, the understanding of its dynamics is of primordial importance.

2 Why is the understanding of the dynamics of language the primordial goal of linguistic theory?

In our century two aspects of language, which had been still rather obscure one hundred years earlier, became clear (Saussure gave his famous lectures in 1910/12).

- a) Language is a latecomer in human evolution and its rather quick emergence as a biologically stable capacity builds on a long story of cognitive and social evolution. Therefore, most of its principles refer to contexts of selection prior to the existence of spoken, grammatical languages (cf. Wildgen, 2004).
- b) Language uses the neural dynamics of our brain, which are not hard-wired and externally programmed like a computer, but rather the result of spontaneous, complex and adaptive brain processes. They are not rule governed like a cooking book or controlled by scripts and schemas like a robot. Brains do not work like this. We know this since we can see the brain working via brain scanning, and this technical advance had an effect similar to the use of the telescope for Galileo in 1610; i.e. many speculative questions became suddenly pointless as they could be assessed empirically.

The proper linkage between evolutionary dynamics (from 35 million to 50,000 y.) and neural dynamics (in microseconds) is given by historical language change (the major topic of 19th century philologists) and by language acquisition (a central concern of early psychologists since the end of the 19th century). Together they specify the major concerns of a dynamical theory of language:

Uncover the principles and if possible the natural laws which have not only triggered the evolution of human language capacity and its historical unfolding, but which also govern language acquisition and spontaneous language use.

As the evolutionary processes in human biology depend on the evolution of surrounding ecologies (their physical and biological changes) and on the physics and chemistry of brain processes, the explanatory strategy in linguistics is linked to general questions of physical, chemical and biological dynamics. The dynamic point of view forces linguistics to give up the Cartesian two-world-view (matter vs. mind / sciences vs. humanities) and engage into the

naturalization of linguistics. This does not mean that the methodological autonomy of linguistics will be abandoned, but rather that this autonomy is just a consequence of our lack of knowledge and access to observation, and not a virtue we must defend when a chance to naturalize the theory of language appears. However, premature and contentless naturalizations are not helpful; they rather hide the difficulties which have still to be mastered.

Historically, dynamic and cognitive linguistics have very few things in common and result from totally different endeavours. The communality is given by a focus on interdisciplinary studies in which biological/psychological questions provide the basic motivation. In René Thom's proposals a long tradition of thought from Leibniz to Poincaré, which led to mathematical results in the 40s and 50s (Thom, Mather, Arnold) and to a rush for applications (cf. Zeeman, 1977), is the starting point. Thom was guided by his discussion with Waddington on biological morphogenesis and expanded this thought to linguistics.

3 Are there domains, where the dynamics of language can be studied successfully?

This question presupposes a kind of local ontology (Husserl has coined this term in his *Ideen I*; i.e. Husserl, 1913)⁴; i.e., we cannot explain the whole phenomenon, but rather have to choose regions, or perhaps islands, for which some insight into the laws of dynamics is possible. We call this the *local explanatory strategy*. These bridge-points can be used to explore further the large fields which have not yet been explored. A guideline in the search for such islands is given by the existence of advances in the natural sciences. We may ask therefore which kind of dynamic laws have been found in physics and chemistry (including evolutionary biology and neurology) and how they are related to linguistic phenomena. The bulk of insights into dynamics have been concentrated in the conceptual structures of mathematics concerned with kinematics and dynamics, i.e., calculus (differential equations), differential topology and dynamic systems theory. The central core of this field is given by catastrophe theory (in the larger sense given to this term by Arnold, 1996). Chaos theory and stochastic dynamics (cf. Prigogine, 1980 and Haken, 1983) have meanwhile enlarged the field and led to a bulk of applications in almost every academic discipline. I shall explain in the

⁴ The philosophical debate of the positions of Kant and Husserl and their modern applications in the humanities was developed in Petitot (1985: 279-293) and further elaborated in Petitot (1992: chapter 2). Petitot does not just reduce objectivity to forms of lived experience, but assumes with Kant that there are schematisms and apriori forms underlying such experiences. Contrary to Kant, he assumes that such aprioris are neither formal nor material; they are rather historically constituted and non absolute; the categories are rather regional and not universal (cf. Petitot, 1985: 286). In the English version of the conclusions (Petitot, 2003: 262) he says the following about his own mathematical-phenomenological position: "it 'roots' structures in the mind while still claiming that they share emergent (supervenient) objective features."

following some major principles of structural stability, stable unfolding and chaotic attractors (cf. Wildgen, 1982, 1985, 1994, 1999, 2005 for elaborations).

Kepler's law for planetary motion around the sun was a break-through in physics; later, this could be explained by Newton's laws of gravitation. Mathematically, the cyclical motion of a planet is an example of the more basic dynamics of a pendulum. The attracting rest-point of the pendulum is a point, whereas the attractor of a planet has one further dimension; it is a limit-cycle, i.e., instead of a point attractor we get something very near to a circle (in fact Kepler showed for the motion of the planet Mars that it has rather an elliptic trajectory, but most of the planetary trajectories are near to circular). In differential topology these insights have led (since Poincaré's work) to the theory of structural stability. Planetary systems and other predictable dynamic systems are structurally stable and the simplest prototype of this behavior is described by a pendulum, its attractor/repellor and the parabolic curve of the potential V mapped against the internal variable x . Figure 1 describes the two critical points of a (dumped) pendulum near its attractor and its repellor (the repellor is only reached if the pendulum goes over head). The basic formulas are $f(x) = x^2$ (attractor) and $f(x) = -x^2$ (repellor). If the pendulum is not maximally damped (e.g., if it is a free swinging pendulum) we must add the wave-motion around the attractor, which is described in complex space, i.e., with the addition of a term which contains the imaginary roots based on $i = \sqrt{-1}$.

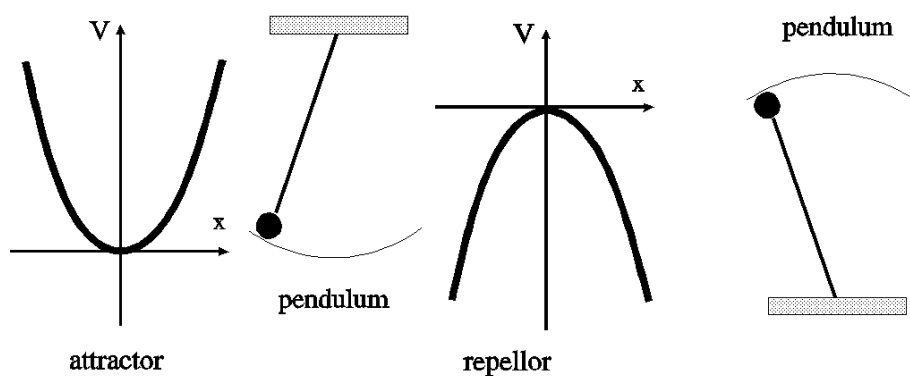

Figure 1: Two basic types of dynamics: stability (attractor) and instability (repellor).

In catastrophe theory, it has been proved that one can add constants and other quadratic functions (y^2, z^2, \dots) or deform the scales continuously without destroying the stability of this prototypical dynamic system, i.e., the system does not change its form, and it does not unfold to more complicated or even to chaotic systems if slightly disturbed. These dynamical systems are like small islands of stability (order) in a universe full of disorder and instability.

Beyond this prototype of dynamic order, we find a restricted class of systems which change if the system is disturbed slightly (mathematically we add functions with further variables but with small constants). They follow a predictable route if they change. The basic result (a theorem proposed by Thom and proved by Mather) gives a classification of such systems with one or two internal parameters and a growing number of unfolding (external) parameters (they control the unfolding process). The most basic (compact) catastrophes are the *cusp* $V = x^4$, unfolding $V_u = x^4 + ux^2 + vy$; the *butterfly* $V = x^6$, unfolding $V_u = x^6 + ux^4 + vx^3 + wx^2 + tx$; the *star* $V = x^8$, and unfolding the $x^8 + ux^6 + vx^5 + wx^4 + tx^3 + sx^2 + rx$. There are dual forms (+/-) and quadratic terms Q that may be added freely.

The characteristics of these systems, i.e., the maximal number of stable regimes and their frontier-lines, are described in Figure 2.

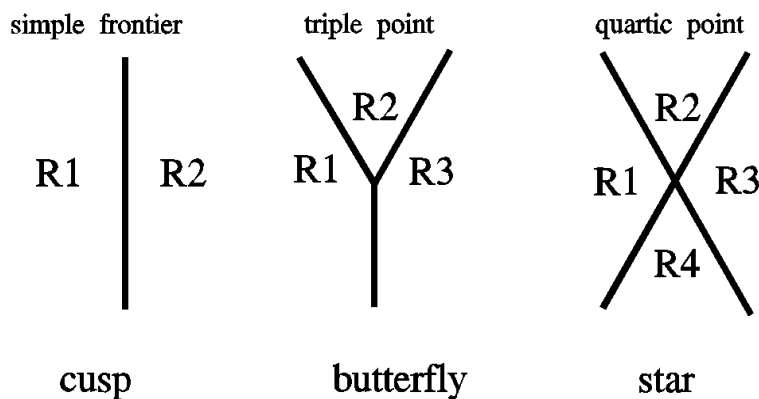

Figure 2: A first hierarchy of dynamical conflicts typical for the compact catastrophes “cusp” (A_3), “butterfly” (A_5) and “star” (A_7).

In the case of the cusp two regimes meet on a catastrophic limit, which is a line. Every point on this line is near two regimes, and the smallest change in the unfolding parameter makes the system shift from one regime to the other. This feature motivates the term “catastrophe”. In the butterfly a triple point exists where three regimes meet; this triple point shows a higher level of instability than the cusp because minimal changes may influence whether the system moves either to R_1 , R_2 or R_3 . In the case that stochastic forces act on the state of the system, it may occur that the triple point switches from one regime to the other and never comes to rest. In the case of the star, a quadruple point appears. The list of cuspoïds, as this series is called, goes to infinity (x^{10} , x^{12} , x^{14} for compact catastrophes).

If we have two internal parameters (in physical terms two different forces governing the system), the list of stable unfoldings stops with the parabolic umbilic ($V = x^2y + y^4$). All systems with two internal parameters and higher exponents, and those with three or more internal

parameters, have no finite set of stable unfoldings. This means that they cannot be classified by a finite set of prototypes.⁵

The mathematical field has been systematically enriched by the consideration of strange attractors and chaotic systems. They also show a system of attractors/repellers and bifurcations, but the attractors may be non-periodic and the bifurcations can be iterated very quickly. Figure 3 shows a chaotic system (Rössler-attractor) and Figure 4 the iterated bifurcations in a Feigenbaum-scenario.

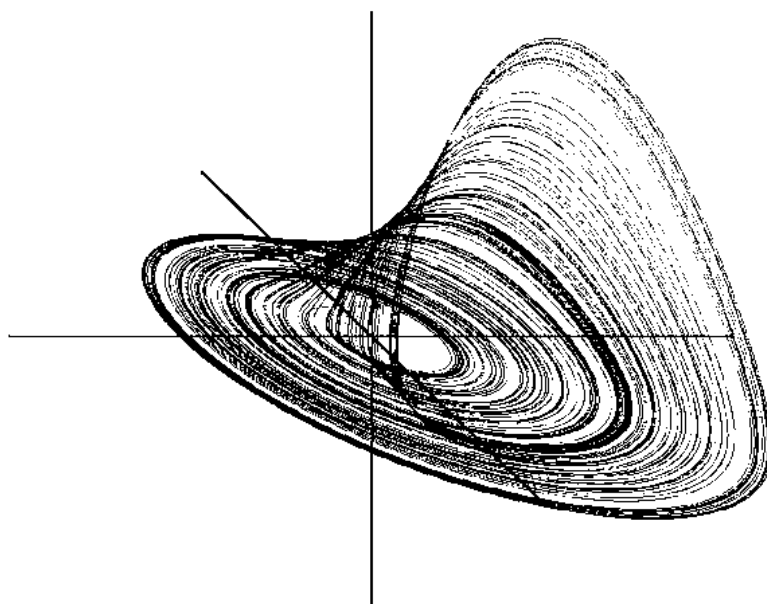

Figure 3: Rössler-attractor (in the case: $a = 0,035$; $b = 0,46$; $c = 4.5$; cf. Wildgen and Plath, 2005)⁶.

⁵ The insights contained in catastrophe theory generalize geometrical insights. Thus the cuspoïds, which form an infinite series, correspond to regular polygons in geometry. The umbilics (unfoldings with two parameters) correspond to the Platonic solids (five in number). Applications of catastrophe theory to nature and man are therefore a generalization of Plato's cosmology and psychology in his *Timaeus* for the relation between psychologically motivated prototypes and mathematical schematisms cf. Fn. 3. In current cognitive linguistics (cf. Wildgen, 2008: chapter 3) prototypes are rather considered as psychological categories transferred to linguistic labels. Such a position ignores the social character of most prototypes and their relevance for mathematics and natural sciences, i.e., their contribution to "objectivity".

⁶ The basic set of equations contains the variable y twice, which induces a reinjection of its value into the system: $dx/dt = -y - z$; $dy/dt = x + ay$; $dz/dt = bx + cz + xz$.
Dynamicturn2008korr2.doc

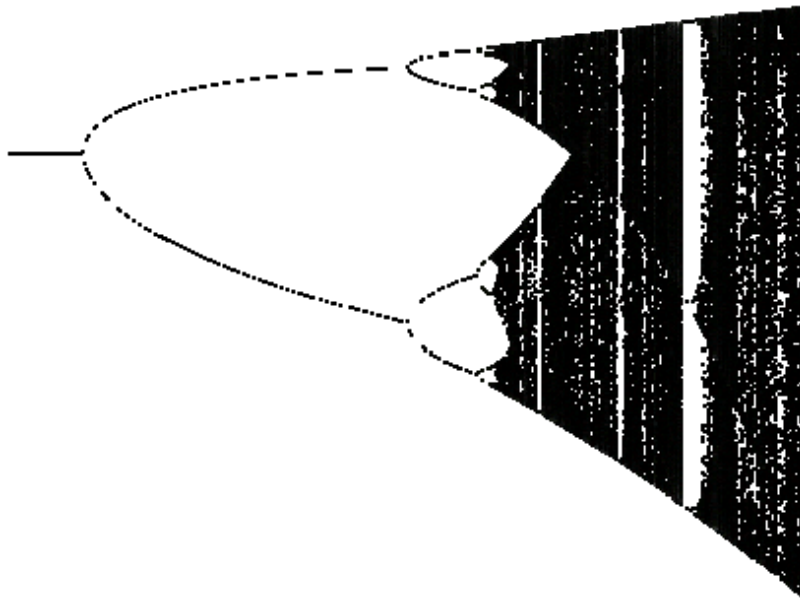

Figure 4: Feigenbaum-scenario (the constant k increases from 2 to 4 horizontally, whereas the vertical dimension concerns the state x . At $k = 3$ the curve splits; at $k = 3,58$ the “tree” has infinitely many branches.⁷

After these very general summarizing remarks on dynamic systems theory, I shall return to the field of humanities, and more specifically to human language. Insofar as it has systematic and regular features⁸ in its evolution and change, emergence, and spontaneous creation, it should correspond to one or several of the prototypes derived in dynamic systems theory (I have only sketched the most basic ones, cf. Wildgen, 1985, for a fuller account). The hypotheses, which have to be elaborated and tested systematically, are:

- a) Major evolutionary transitions have the character of a stable unfolding and one should search for the (restricted number of) forces which control them.
- b) Although language change is driven by many factors distributed in geographical and social (psychological) space and acts differently on many levels of a language, major and lawful changes (cf. the “Lautgesetze” of the Leipzig-school called “Junggrammatiker”) should have an unfolding character and match one or more prototypes in Thom’s list (or exhibit some type of chaotic behavior).
- c) In language acquisition, the transition between non-language (crying, babbling, mimetic response) to first levels of grammar and the learning of constructions via generalization from usage (cf. Tomasello, 2003) should manifest unfolding characteristics.
- d) In the brain-dynamics, which assemble communicative impulses and create sentences and texts, transitions which give a definite shape to prelinguistic thought have to be

⁷ The underlying logistic mapping is: $x \rightarrow kx(1-x)$; cf. Stewart, 1990: Chapter 10.

⁸ The stochastic and chaotic potential of human language is neglected but not ignored in the following passages.
Dynamicturn2008korr2.doc

assumed. The distributed and uncoordinated dynamics of assemblies must acquire (for short time intervals) the stability necessary for the emergence of an utterance. Stability theory may explain this phenomenon.

As grammar describes mainly the processes in (d) and its prerequisites (acquired in processes of type c), I shall concentrate on this field (cf. Wildgen, 2004, for field a).

Grammars have been a central concern of scholars since antiquity and I shall take *cognitive grammar*, a contemporary outcome of this longstanding tradition, as a starting point. As these grammars have a programmatic link to thought, vision, and memory and ask for an integration into current brain science, which stands in the tradition of physics (cf. neural nets) and calculus (cf. Petitot, 1992: 293ff), we can ask if the major regularities shown in cognitive grammar can be formulated in terms of dynamic system theory such that the hypotheses of some underlying unfolding processes can be tested.⁹ I have chosen three central concerns of cognitive grammar (cf. for a critical overview in German Wildgen, 2008) to test this assumption:

- Force dynamic (Talmy)
- Metaphorical mapping (Lakoff)
- Construals (Langacker)

4 The treatment of dynamic features in classical “cognitive semantics”

The research line of *cognitive* linguistics in general since the 50s may be situated in an interdisciplinary but rather technically minded world: one of information theory (Shannon) and cybernetics (Wiener). This world was developed in the philosophical atmosphere of logical empiricism (Quine) and formal syntax (Carnap). Whereas Chomsky elaborated this field and created a compact mentalistic theory, Lakoff (since 1975) and with him Langacker and Talmy combined insights of gestalt-psychology and modern computer vision with ideas stemming from issues of generative semantics. It would be too lengthy to follow the

⁹ The dynamic enterprise is neither objectivistic (in the definition of Lakoff (1987: 160) “[a]ll of reality consists of entities, which have fixed properties and relations holding among them at any instant”) nor is it “experiential” (“experiential realism characterizes meaning in terms of *embodiment*”; *ibidem*: 267). Embodiment is only an aspect of natural phenomenology (highlighted by Merleau-Ponty, 1945 in his elaboration and critique of Husserl). All enterprises which tried to reduce natural sciences (mainly mathematics) to sensations or primary experiences fell short of their explanatory goal.

development of both lines of research in detail.¹⁰ Historically, dynamic and cognitive linguistics result from different endeavours. The communality is given by a focus on interdisciplinary studies, in which biological/ psychological questions provide the basic motivation.

4.1 Force- dynamics and the semantics of prepositions and (causal) connectors

In the realm of cognitive semantics, Talmy's paper on "force dynamics" (1988) was almost an invitation to apply dynamic systems theory. Nevertheless, philosophical barriers prevented such an application (cf. Lakoff 1987 and his opposition between experientialism and objectivism). In the following, I will propose several points of transition between cognitive semantics and dynamic semantics.¹¹

The material on which most of Talmy's analyses is based are two sets of examples with a closed class term at their centre, either a preposition (a) or a connector (b).

a) The ball sailed *past* his head.

The ball sailed *through* the hoop.

He ran *around* the house.

He walked *across* the field.

(Cf. Talmy, 1975: 201-205)

b) The ball kept rolling *because* of the wind blowing on it.

The shed kept standing *despite* the gale wind blowing against it.

(Cf. Talmy, 1988: 5)

Whereas in the treatment of the meaning of verbs Talmy just refers to predicate constants like MOVE and CAUSE (cf. Talmy, 1975 and 1976), he introduces "imaging systems" in Talmy (1983) which refer to "abstract geometric characterizations", a "mental eye" for the analysis of the examples under (a), and "force-dynamics" for the examples under (b).

It is clear, and the pictures in Talmy's article demonstrate it, that the examples in (a) use notions of space, border, transition, and motion that may easily be modelled in dynamic

¹⁰ Wildgen (1994: chapter 1) and Wildgen (1999: chapter 1) contain a critique of image- and schema-centred cognitive semantics and embed these endeavours into a larger historical framework. A broad overview is given in Wildgen (2008; in German).

¹¹ The adoption of specific philosophical positions in linguistics is by and large a political strategy and does in most cases not essentially contribute to the advance of our knowledge in this field. Philosophical questions can neither be an apriori of empirical research nor can they be proven post hoc; they may, however, encourage specific endeavours.

system theory. In the following I shall just sketch the lines of such an elaboration. In the sentence “He walked across the field”, the field is a topologically coherent surface (it does not contain islands or other bounded areas) with a boundary, which may be crossed (entering/leaving the area).¹² We have two dynamics: slow (stable) and quick (transitory) dynamics. The latter corresponds to one of the two types; i.e., an attractor is found or a repeller is avoided. The verb “walk” focuses on the stable (slow) motion, with an implicit ingressive (start) and egressive (stop) phase, whereas “across” focuses on the quick dynamics of change, called a “catastrophe of bipolar change”. Figure 5 shows such a scenario.

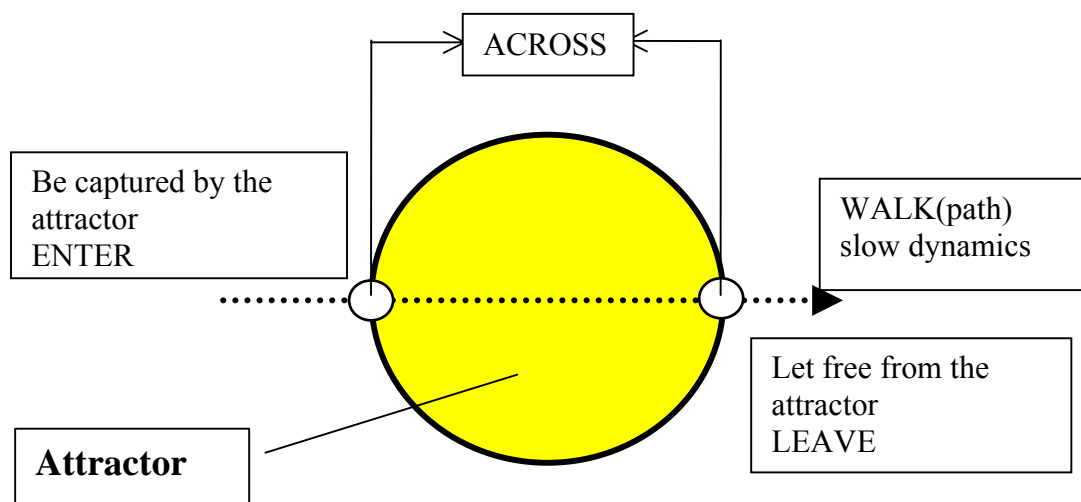
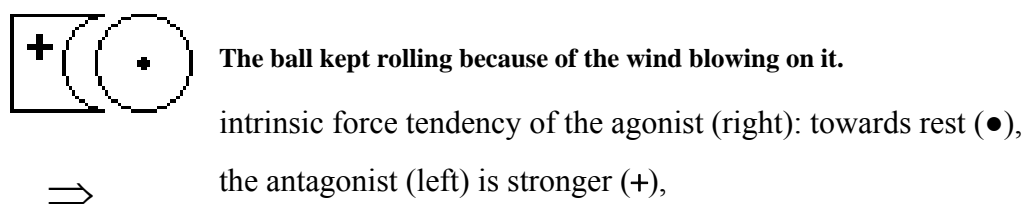

Figure 5: Catastrophe theoretical description of the major dynamic meaning components in the sentence.

Talmy’s “force dynamics” use (and presuppose, as no definition is given) the notions of “rest” and “action”. These labels correspond to the notions of “attractor” and “catastrophic transition” (change). The notions of “force tendency” and “result of force interaction” are, however, beyond catastrophe dynamics because one needs an energy-flow with loss and gain of energy, i.e., a thermodynamic model. Nevertheless a basic schematisation in terms of stability theory may stand for the simplest level of Talmy’s pictographic description. Figure 6 shows Talmy’s pictogram and descriptive additions.



¹² If the boundary is not crossed, different choices are left. Talmy mentions the movement *along* the boundary. Further differentiations can be added as in: *She turned around the corner* (suggestions by a referee). In English a number of different spatial relations expressed by prepositions or in the verb-stem can be combined.
 Dynamicturn2008korr2.doc

intrinsic force tendency of the antagonist: action,
 result of the force interaction: action (\Rightarrow).

Figure 6: Schematisation of force-dynamics by Talmy (1988).

The rather cryptic pictorial description of force-dynamics by Talmy has to be decomposed in a dynamic model. In Figure 7 only the catastrophe theoretical part is represented via diagrams, whereas the thermodynamic modelling is expressed via ordinary language descriptions, which can, however, be replaced by a mathematical modelling, which is too technical to be introduced here. In terms of qualitative dynamics, the energy goes to zero (by diffusion) and would thus correspond to a catastrophe of death (of motion). The coupling of the two systems (ball/wind) prevents the catastrophe and thus produces the process shown under C.

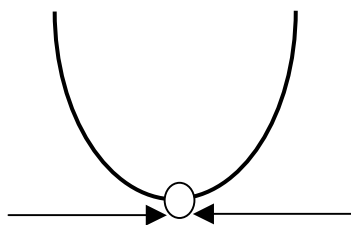

A. *roll* : motion (attracted by a position of rest). The picture above shows the dynamic system $f(x) = x^2$, the parabola describing the motion of a pendulum attracted towards its position of rest.

- B. *blow*: energy gain, which causes the motion to continue although it is attracted towards a rest position.
- C. *because*: causal link between energy gain and natural (diffusive) loss of energy
- D. *keep*: equilibrium between loss of energy and (added) gain of energy;
 unfolding along a path vertical to the attractor

Figure 7 : A dynamic decomposition of Talmy's description

Both forces “roll” and “blow”, underlie the thermodynamic diffusion law, are linked in order to form a coupled dynamic system (“because”) and achieve (at least) equilibrium of energy loss and supply. The connector thus stands for the dynamic coupling of two systems.

The coupling of two dynamic systems has been analyzed in the case of physical systems (the classical case are coupled oscillators and resonance phenomena). The dynamic systems approach produced the interdisciplinary field called “synergetics” by Herman Haken (cf. Haken, 1983). This has been applied to cognitive systems (cf. Haken and Stadler, 1990 and Haken, 1996). Haken (1996: chapters 5 and 6) and Kelso (1995) studied the coupling of finger movements of animal gaits, but Haken (1996: part III) applied the methods of synergetics also to effects of synchronization and desynchronization shown in EEG and MEG pattern. Oullier

et alii (2004) expanded this paradigm to imagined sensorimotor coordination. In the case of an adjunct (adjective) coupled with a head noun one could imagine an application of this methodology if a proper dynamic model of single word meanings is available.¹³ The major difficulty is that many simplex word-concepts are semantically already complex since they involve different sensorimotor parameters, abstraction, metonymy, and metaphor. The syntactic composition of words must therefore first consider a kind of frozen complexity at the word level and build a syntactic operation of meaning composition on this basis.¹⁴ This is surely not a simple enterprise, but I cannot see how an interesting theory of grammatical composition can be developed without solving these problems.

If every sentence is mapped to a simple catastrophe scenario, the different connectors for “CAUSE” would couple these systems. Characteristic outcomes could be selected by the choice of a specific connector; e.g., because, despite, etc.

Although the dynamic system approach destroys the simple pictorial illusion in Talmy’s models, it pinpoints basic problems hidden in Talmy’s description.

(1) There is a mapping between physical dynamics (the wind, the ball), the perception or the imagined enacting of the process, its memory trace (with abstraction) and the linguistic expression. The first levels are hidden in Talmy’s description of force dynamics in Talmy (1988), although his terminology and pictures presuppose their existence. Thus part of the “cognitive aspect” is veiled by his description.

(2) The semantics of complex sentences blend different types of dynamics:

- Spatio-temporal dynamics with attractors and catastrophes
- Energy functions and the coupling of subsystems

In a full-fledged cognitive analysis, a bridge to models of the external world, of perception, motor-control, memory, and senso-motoric imagination¹⁵ must be established, which will involve the disciplines of physics, psychology and neurology. If social action and interaction, social relations and conflicts are expressed in a sentence or a text, models of social action proposed in sociology and social psychology and their mental correlates have to be

¹³ Traditionally a sharp distinction between the operation of connecting sentences and combining words is made. The difference rather concerns the combined aspects. In connecting sentences, temporal/spatial and causal features are prominent, whereas in the composition of words or the adjunction of words to a head constituent form and quality features may be highlighted. The neural operation seems to be a similar one. In the case of N+N-compounds (without a verbal or prepositional constituent) implicit causal connections may surface in the interpretation of the compounds (cf. Wildgen, 1987). I thank one of the referees for his/her remarks.

¹⁴ In Wildgen (1987) first steps are made with reference to nominal composition (nonce-compounds in German). For first steps towards a neurodynamic model of semantic composition cf. Wildgen (2006b) and section 4.

¹⁵ Cf. Oullier et alii (2004).
Dynamicturn2008korr2.doc

considered. The “splendid” methodological isolation of cognitive semantics precludes a truly *cognitive* model of meaning in language.

4.2 Metaphorical mappings

The Aristotelian notion of metaphor is formulated in terms of a proportional equation:

life / day = death / night or *youth / morning = age / evening*

The proportion assumes the transfer of a relation (life/death) from the domain of human life to the domain of world-rhythms (sunrise – sunset). As Lakoff’s and Johnson’s orientational metaphors show (cf. Lakoff and Johnson, 1980: chapter 4), a whole set of structural relations in the domain of body parts and bodily experience (up/down, front/back, right/left, hand/eye/ear) can be mapped to abstract domains and thus provide a rather simple and stable pattern for the domains like feeling, mood, desire, and responsibility, where not such simple and stable structures are experienced. As Talmy (2007) says, the semantic structure of embodied domains is reused and replicated for more abstract domains. Aristotle’s intuition of a transfer of proportions was right, insofar as stable relational patterns may prototypically be understood as musical harmonies; i.e., simple ratios like 1/2, 1/3, 1/4, 1/5, etc.

If two extremes of a linear scale (big/small, young/old, up/down) are used, the ratio is 1/2, and if an intermediate stage is considered (hot/warm/cold, child/adult/senior) the ratio is 1/3, and so forth. The dynamic analogue is the cusp (two regimes), the butterfly (three regimes), and the star (four regimes). Thus the geometrical intuition of Aristotle’s notion can be dynamically formulated in the framework of catastrophe theory (which inherits basic insights of Plato’s mathematics). Slogans like *argument is war* or *love is a journey* introduced by Lakoff and Johnson (1980) may control the mapping of a whole encyclopedia related to *war* or to *journey*, or to another encyclopedia of notions referring to *argumentation* and *love* affairs. The basic features in these cases are *selection* (i.e., only one part of the encyclopedia is recycled) and *change in perspective* (further principles have been named in the model of conceptual integration by Fauconnier and Turner, 2002). Thus, if *love* is considered as a *journey*, it would be rather pleasant, short and easy going. In the case of *love is craziness* or *love is war* very different aspects of love experience are foregrounded. It is most likely that there is an infinite number of perspectives that are possible (some are more frequent than others, and they depend on cultural traditions). The question beyond the illustrative treatment by Lakoff is the following: Are such seemingly arbitrary selections and perspectives stable, repetitive and, therefore, transmittable between subjects or even cultures? If yes, how is this achieved?

The phenomenological position chosen by Johnson (1990; in the tradition of Merleau-Ponty, 1945) is called *embodiment*. René Thom's had years before proposed the notion of *semantic density or depth*. It "postulates that there exists a certain isomorphism between the mental mechanisms which ensure the stability of a concept Q, and the physical and material mechanisms which ensure the stability of the actual object K represented by Q. ... It follows that the more 'complex' a concept is, the more its stability needs regulator mechanisms, the greater is its 'semantic density'" (Thom, 1983: 248, based on an article published in 1973). Early experienced body related phenomena are semantically more dense than later experiences which cover a larger area of human ecology and are more numerous. Instead of body/world a finer scale is needed, which contains at least:

1. Biologically general, species-specific processes/entities (like the human body).
2. Ecologically central processes, like human locomotion (of eyes, hands, feet) and basic actions on objects (have, grasp, eject).
3. Socially mediated processes and objects (give, receive or positive/negative forces), social relations (mother/father/siblings), values (good/bad), language, etc. They are experienced in the context of primary socialization (in families or care-giving contexts).
4. Cultural techniques and the bulk of knowledge learned after primary language acquisition and mediated by language.

René Thom (1988: chapter 2) called the underlying dynamics the diffusion of "pregnancies". The metaphorical process is the unfolding of primary pregnancies (meanings) into a rich encyclopedia of human knowledge (which is linguistically mediated). Lakoff's metaphor hypothesis is just the peak of this iceberg.

The fundamental *cognitive* problem of a semantics of embodiment concerns the nature of the mapping from non-linguistic embodied concepts to simple linguistic terms (body-near), and from there to more abstract levels (social experience, intellectual activity). The questions, which must be asked, are:

- How stable are such mappings?
- What happens, if the mapping is iterated? Does it go to chaos?
- Are there limits of complexity of a source space (in terms of dimensionality, number of components, etc.) for a stable mapping? If yes, what is the limit and why?

- Is there some intermediate transpersonal (social/cultural) level which has its own forces of stability (e.g. tradition, social selection)? Does it build a platform (e.g. a folk-theory) from which stable constructive processes can start?

Maps are interesting, if they select characteristic features and forget other ones. They should also preserve a basic structure (the “kernel” of the mapping). In most interesting cases, they also reduce the dimension of the object mapped. Thus a geographer may conserve distance but change angles or vice versa and he/she normally projects a surface in three dimensions (the surface of a sphere) on two dimensions. A schematic road map may even be one-dimensional and preserve just the distances on a path.¹⁶

In the case of embodiment, our bodily self-perception is basically three-dimensional, and it may be mapped on a set of one-dimensional scales in language, like: on top of – at the bottom of; in front – behind; at left – at right. If several senses are implied, like vision (of parts of our body), hearing, smell, etc., and inner states (emotions), the embodied space of pre-linguistic meanings can have many dimensions which interact, have vague borders, etc. Under these conditions a mapping to some mental representation (memory) and to language should normally be unstable. If the mapping is iterated, e.g., from self-perception of the body to the perception of the other, to memory, imagination, linguistic schemata, and to situated utterances, the instability increases dramatically. At all levels very specific controls must exist in order to guarantee stability (and prevent chaotic or input-neutral results). When there is a high level of stability of the primary mappings, a body-mind-language must be presupposed if metonymic and metaphorical mappings should preserve stability (although they increase vagueness and ambiguity). For metonymy a stable segmentation of wholes into parts must be presupposed, and for metaphor the existence of a similarity- (or nearness-) measure which may control transitions like *love IS a journey*, *love IS fire*, and *argument IS war* must be assumed. Lakoff and Johnson ignore the question of segmentation in a continuum and assume that a segmented universe of semantic entities already exists. Langacker (2006) has discussed the issue of continuum versus discreteness. Nevertheless, all current cognitive models in this tradition stick to the classical structuralist ontology of a world and a language consisting already of properly segmented entities. The proper aim of linguistics is therefore to classify these entities and describe the combinatorial restrictions on a free algebra defined on discrete and finite sets (of phonemes, morphemes, words, or basic clause types).

¹⁶ Cf. Wildgen (2006a) for the differences of mappings between texts and pictures.
Dynamicturn2008korr2.doc

It is known from chaos theory (cf. Peitgen et alii, 1992: 277 ff. and for an application to language Wildgen, 1998) that even in the case of a two-dimensional input, like that on a video-screen, an imperfect map to itself produces chaos after some steps only.¹⁷ In classical cases it has an attractor intrinsic to the system itself and totally independent from the input. The input information is lost and the iterative process is “frozen” into a standard pattern. A classical example of such a frozen result of self mapping under deformation is shown in Figure 8 and is called the Sierpinski triangle.¹⁸ In real cognitive processes, mappings may therefore produce one out of a small set of stereotyped images which are emotionally preferred (haunting images).

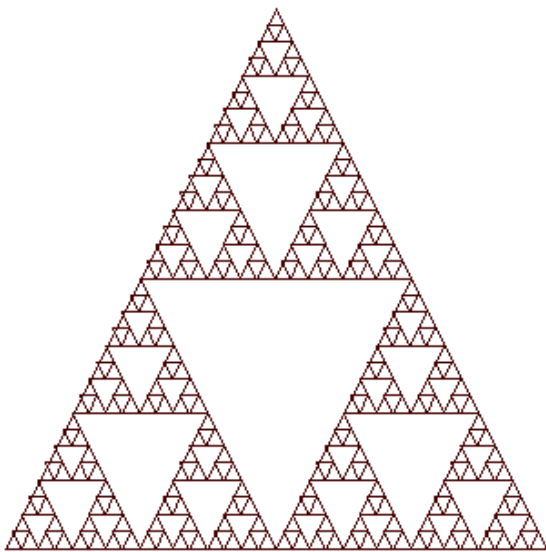

Figure 8: The Sierpinski triangle as a standard attractor of a chaotic mapping process.

Thus one can predict that the probability of a “simple” and efficient map with higher dimension and noise in the case of body → mind → language (item 1) → language (item 2) → ... is near to zero. Two consequences may be drawn:

1. The semantic space of representation must be low-dimensional.

¹⁷ Peitgen et alii, 1992: 30 ff., conceive a multiple reducing copying machine with a collage of three reduced pictures to one new picture in a triangular constellation. After three copies all pictures converge to a picture similar to the Sierpinski triangle, but the Sierpinski triangle is invariant under the operation. It is clear that this example is extremely simple and that in mental mapping many kinds of deformations occur. The idea that some internal attractors exist which override external stimuli is cognitively plausible given the observations on early developmental stages, self-organizing processes in the brain, and their failures in the case of autism and other deviations.

¹⁸ The Polish mathematician Waclaw Sierpinski lived from 1882 to 1969.
Dynamicturn2008korr2.doc

2. The evolutionary older mapping body-mind → (non linguistic) action is the launching ground from which the younger and less stable linguistic mapping can start. ¹⁹

These are the most plausible assumptions underlying any semantics of embodiment.²⁰ A consequence is that cognitive semantics needs an evolutionary questioning, which may be concentrated to the question: Where does meaning come from?

4.3 “Construals” in cognitive grammar (Langacker)

Whereas Bloomfield (1926/1987) reduced meaning to stimulus-response-patterns and gave the responsibility for its treatment to psychologists,²¹ cognitive semantics has to consider a meaning for all constituents in terms of a cognitive representation, and it must also specify the composition-process as a meaningful operation. I will just comment on two simple examples of Langacker’s procedures:

1. The representation of the verb ENTER in Figure 9, taken from Langacker (1987), shows two stages of his analysis. In the upper picture a non-minimal number of stages (snap-shots) of the process are considered. If the number 5, chosen by Langacker, increased and approached infinity we would obtain a continuous process described by a differential equation. In the second picture, only a minimal number of phases (n=3) is considered; in fact one could eliminate the intermediate picture and would arrive at the traditional notion of a starting-state and an end-state (e.g. in the logics of action of von Wright, 1966). Langacker’s notation stops midway between a logical model (two states - one predicate of change) and a continuous model (an infinity of stages and a smooth function of time). In terms of cognitive modelling, he falls back into the non-dynamic schematics of logical models.

¹⁹ Prof. Heli Tissari suggested in a comment to this paper that the etymology of ‚fear’ gives hints to non-linguistic acts, such as escape.

²⁰ This kind of insight was already exploited in the work of Husserl and other phenomenological thinkers at the beginning of the 20th century.

²¹ Bloomfield (1926/1987: 72) states: “ a meaning is a recurrent stimulus-reaction feature which corresponds to a *form*. A major aim of his postulates was: “in particular it cuts us off from psychological dispute” (ibidem: 71). Chomsky continued this strategy insofar as his competence model is cut off from the performance model which may be tested by psychologists.

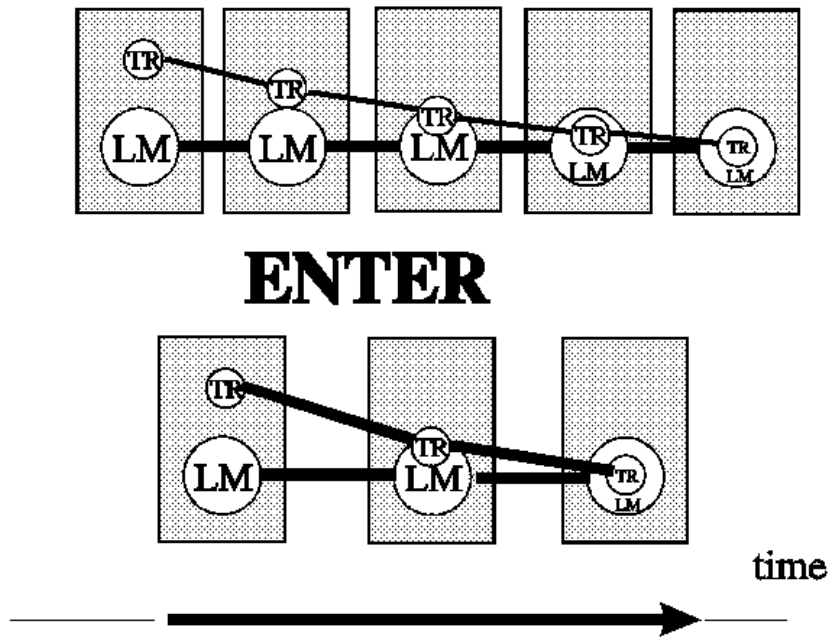

Figure 9: Langacker's analysis of the verb ENTER.

2. In the space-representation of the proposition *the man found the cat* and the picture for FIND resembles the picture for ENTER *topologically*, the main difference is the specific filling of the landmark by an entity. Whereas in the construal of ENTER the landmark (LM) specifies the spatial background on which the process (ENTER) is defined, the bivalent verb “find” requires *two* specific spaces corresponding to MAN and CAT and the spatial background (WHERE) is out of focus. The dichotomy of TR and LM is not able to catch this important difference between ENTER and FIND.²² The constituent structure is interpreted as a hierarchy in the filling of the open slots (categories) in the pictorial representation of the verb FIND (cf. Langacker 1984: 13).

The “dynamics” is reduced to a set theoretical sequence shown in Figure 10.

²² If a model of saliency was applied, one could distinguish different degrees. In the FIND-scenario the spatial domain of MAN is “entered” by the cat, if the man finally takes the cat into his arms, and the man (and the cat) are part of some spatial domain which is more global than the bodily domain of man and can thus be left unspecified. A theory of saliency is, however, not explicitly developed by Langacker. In a dynamic perspective, one could say that the transition (catastrophe) is the most salient feature, and it selects the domains relative to the transition point. In the case of ENTER, the space of locomotion is the proper embedding of the transition; in the case of FIND, the space of CAPTURE is the relevant embedding, and it is centred in the body of the person who searches the cat. I would like to thank a referee for this comment.

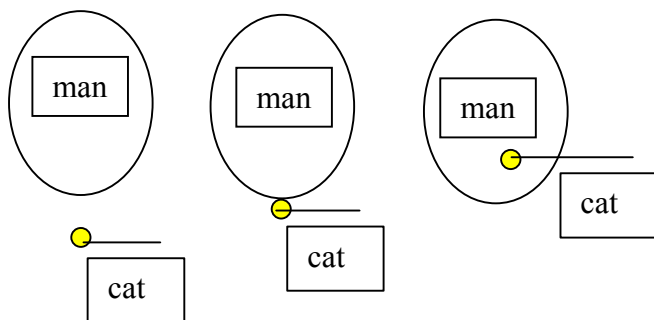

Figure 10: The “dynamics” in Langacker's analysis of : *the man found the cat*.

The “dynamics” consist just in an aggregation of three set-theoretical situations, which are rendered by quasi-topological Venn-diagrams:

- No intersection between set M (man) and set C (cat),
- Set M and C have one point in common (tangency),
- Set M includes set C.

This representation contains neither an intrinsic time-scale (and motion on this scale; i.e. kinematics) nor does it specify any forces (i.e. dynamics). Thus it is even more static than Talmy’s models that introduced a kind of folk-dynamics, which could be further specified in dynamic terms. Even at this low level of modelling, it remains totally obscure where the difference between ENTER and FIND lies semantically, let alone to ask for the difference between *find*, *catch*, *eat* and other bivalent asymmetric verbs. Contrary to Langacker’s model (cf. Wildgen 2008: 133-140 where different treatments of valences and processes by Langacker are compared), the catastrophe theoretical model for CATCH specifies a topology (a poor geometry so to say), has two types of dynamics (quick dynamics of vector fields and slow dynamics of motion in time), a critical point (bifurcation between two attractors and one), and a rudimentary force defined by the potential V. Nevertheless, it is still dynamically very poor. Thus it is obvious that the 16 archetypes enumerated by Thom (1972) can not differentiate the set of 8000 basic verbs that were examined in Ballmer and Brennenstuhl (1986).²³ In Wildgen (1988) the dynamic decomposition of verbs of motion has shown the strategy for further specifications of the catastrophe theoretical model. It uses results from the psychological study of motion programs and motion perception (cf. several contributions to the Elmau conference 1988 in Haken and Stadler 1990 and Kelso 1995).

²³ The set of classified paths is further augmented in Wildgen (1982) and (1985). In Wildgen (1994: chapter 5) a hierarchy of levels for the interpretation of archetypes is introduced. Nevertheless, the “lexicon” of dynamic archetypes does not exceed the range of 100.

Movements of living bodies and body parts are subject to two types of control:

1. The non-linear control of movements, which is largely independent of specific contextual factors, defines the goal of a movement. Non-linear controls involve catastrophes, i.e. sudden changes in the evolution of a process.
2. The linear control adapts the movement in its metrical detail to specific contextual features, and it "tunes" the qualitative motion-schema.

If we consider simple movements with one or two limbs and look for analogies in physical mechanics, we will find the elastic pendulum and the double pendulum. Figure 11 shows the analogy between a double pendulum and the movement of a human leg. The right-hand side of Figure 11 shows phases in the movement of the human leg while the person is walking (experimental results of Johansson, 1976: 386). The dynamical system of the human leg is comparable to a double pendulum (it is strongly damped and has restricted domains of freedom).

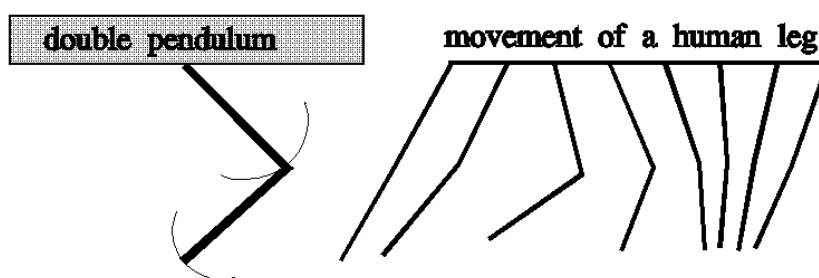

Figure 11 *The motion of a double pendulum and of a human leg*

Two levels of limb-motions can be distinguished:

- a. The rhythm of the composed movements, which is a code for the categorical perception of moving agents.
- b. The overall "gestalt" of the movement.

The coarse topology of locomotion has three phases:

- A. Loss of position of rest, beginning of motion
- B. Steady motion
- C. Gain of a new position of rest, end of locomotion.

The steady motion in phase B is the basic schema, which underlies the semantics of simple verbs of locomotion like *go*, *run*, or *drive*. These have been traditionally characterized as *durative*. Instabilities of a simple type can be added to the basic schema using different types of information:

a. *Intrinsic information* contained in the background schema: "A speaks to B", where A=speaker, and B=listener. The continuous locomotion can enter the field of A or leave it. The prototypical realizations of this schema are:

C comes (towards A = speaker)

C goes (away) (away from A = speaker)

b. *Extrinsic information* given in the utterance or by the context of the utterance, as in:

John enters (the house)

John leaves (the house)

In both cases the underlying topological schema contains an instable form of the type called birth/death (in catastrophe theory). The process of locomotion of a body is either continuous (durative) or it involves an implicit or explicit boundary and an orientation of the process relative to this boundary. The introduction of an orientation defines a goal and introduces a kind of *intentionality*.

The path from the source to the goal can be complicated by the introduction of intermediate forces. We find two fundamental types of intermediate forces in linguistic scenarios.

1. *Instrumental "mediators"*. They modify the mode and the reach of our locomotion. The overall schema remains qualitatively the same; e.g. a traveller going from Hamburg to Bremen can go by foot, bicycle, car, train, or plane.
2. *Causation by agents*. It is a mediation which includes the control of other agents or of natural processes. The attribution of causality is linked to the perception of certain spatio-temporal correlations, attribution of intentionality, and assumption of agency and responsibility.

The cognitive schemata that have been classified here are not only relevant for the lexicon of the verb; they also form the cognitive basis for causative constructions (see Talmy, 1976).

4.4 Further developments in dynamic semantics

The application to linguistics (and other human sciences) had first followed the standards of applied mathematics, and in my work I tried to stick to these standards as far as linguistic methodology allowed it. It became clear that the lack of quantitative and statistical methodology in semantics restricts such a program. The topological nature of elementary catastrophe theory asks for a "rough" modelling by which only general features of the field in question can be captured. In the beginning, the "dynamics of language" must mainly consider critical transitions, bimodal, and trimodal oppositions, etc. Specific predictions or an exact reproduction of descriptive details cannot be the goal of these models because it is by definition a topological (and not a geometrical) model, and all descriptions have to be

interpreted as modulo smooth deformations (diffeomorphisms); i.e., one cannot simply transfer them to the level of metrical measures. This means that only very general questions may be assessed with the help of qualitative dynamics. In the period after 1979 I developed proposals for different linguistic subfields, such as word semantics, verbal semantics, vagueness and ambiguity, nominal composition, dialogue and narrative, phonology, predication and the semantics of time (cf. Wildgen 2005 for a summary). In all cases, specific phenomena that imply structural transitions, the creation (destruction) of category boundaries, and the multistability of lexical and syntactic forms are selected and treated with the help of dynamic systems theory.²⁴

In the following I will consider current models of neurosemantics in order to check if they rather ask for a style of cognitive semantics as proposed by Lakoff, Langacker and Talmy or take a path which is akin to that of dynamic semantics.

5 Semantic composition in neurosemantics

The field of neurosemantics is exclusively based on experimental results obtained in the analysis of neural dynamics measured in the brain of animals, when they assess meaning in their environment (perception, attention, memory), and on neural waves measured in humans during the processing of linguistic tasks. The proposed cognitive mechanisms are neither inferred from high level linguistic performances (and the intuitions speakers share about them), as in cognitive semantics, nor from very general features of dynamic systems, as in dynamic semantics. In this respect neurosemantic proposals are independent from both traditions, and they allow us to judge the cognitive plausibility of both paradigms.

The simplest case of semantic composition can be studied in nominal syntax. Consider a noun; e.g. “square”, an adjective of colour; e.g. “red”, and a present participle; e.g. “moving”:

red moving square

How does the brain compose a head-noun referring to form with two satellites referring to colour and motion? Andreas Engel (2004) distinguishes three major areas for sense related information: the visual system (subdivided into the areas $V_1 \dots V_5$), the occipital areas and the parietal ones. The major binding process is one of temporal synchronization of assemblies, which form wholes (gestalts) from parts, and desynchronization, which distinguishes figure

²⁴ Petitot (1992) established a philosophical link between Husserl’s phenomenology (in his Ideen II) and morphodynamics (the semiophysics of Thom, 1988). In his further work he discussed the link with cognitive semantics. The common basis would be gestalt-psychology and (Husserl’s) phenomenology.
Dynamicturn2008korr2.doc

and ground. The synchronization of two perceived stimuli can be measured in the Gamma-band (30-70 Hz) and the Beta-band (15-20 Hz) of an EEG. The fronto-parietal centres select features that are then passed on to working memory and planning.

Parts or features of a visual whole are linked by the synchronic firing of a set of neurons (an assembly) during a short time interval. In the example, neural assemblies (hundreds or thousand of neurons and their firing rhythms) linked to *square*, to *red*, and to *move* are bound together by the internal synchrony of the assemblies. This type of analysis concerns only the composition in perception, attentiveness and memory, but one may conjecture a parallel process for words and their composition in syntactic constructions involving nouns and adjectives. In experiments with human subjects solving linguistic tasks, characteristic brain-waves (in the gamma-spectrum, i.e. 30 to 50 Hz) have been observed. They are the correlate of synchronization between assemblies in the brain. Semantic separation (distinction) leads to asynchronies which can also be measured in human brains. Composition is therefore in principle characterized by the dynamic behaviour of cell assemblies in different parts of the brain, and the relevant brain-features are the synchrony and asynchrony of firing in these assemblies. Further research has shown that memory and top-down processes in recognition and processing show similar mechanisms. The coding of compositional effects is, therefore, rather dynamic and temporal than static and spatial. This contradicts with a large number of pictures used in cognitive grammar; e.g. by Langacker (1987 and 1993), which reflects the state of the art of cognitive psychology before the advances of neurolinguistics. However, it shows at the same time that the very basic dynamic schemata of catastrophe theoretic semantics have to be elaborated in order to fit the more specific dynamics observed in brain activity.²⁵

As a first consequence one can formulate a desideratum of cognitive linguistics. The basic types of composition of parts (constituents) to produce wholes (gestalts) must be cognitively explained in the case of:

- attribute – noun groups (NP-semantics)
- complement – verb groups (VP-semantics)
- conjunction of sentences (e.g. linked by a connector).

²⁵ Zeeman (1977) had proposed that thoughts correspond to global attractors in the human brain. This view is too rough, insofar as many parallel processes occur in different areas of the brain. Possibly some monitor functions of the fore-brain may achieve one or a few attentional attractors (which become conscious), and these may underlie the schemata we have shown in the section on catastrophe theoretical semantics.

If these basic mechanisms have been further elucidated, we can then begin to build a cognitive grammar which is scientifically founded. Langacker's proposals may be valuable as intuitive hypotheses, which must be specified and critically evaluated in terms of neurological processing.

As a further result one can formulate some restrictions on compositionality due to temporal binding. Teisman (1999: 108) writes:

„It [the binding-by-synchrony hypothesis] also provides a plausible reason for the attentional limit of around four objects that is widely observed in the perception of brief displays and in studies of visual working memory. The different firing rates that can be easily discriminated on a background of inherent noise and accidental synchronies may set a low limit to the number of objects that can be simultaneously bound.”

The restrictions of valence patterns and of embeddings (recursive operations) have been discredited by Chomsky as performance effects. To the contrary, they are hints to the nature of the compositional process in language and thus more interesting than the algebraic notion of recursive operations. Here the application of catastrophe theory to semantics (cf. section 2 and as a summary Wildgen, 2005) has its classical field. Because the complex but structurally stable valence patterns lie beyond the current experimental reach of neurological experiments, the plausibility of dynamic semantics must still rely on a rough isomorphism between patterns in the real world (physical process patterns) and linguistic forms (sentences in different languages). We presume that the brain as the mediating apparatus has the means to map the ecologically relevant aspects of physical processes into stable linguistic patterns.

6 Conclusions

The measurements of ERP and fMRI in experiments involving natural language cannot simply elaborate given linguistic models as those put forward by Talmy, Lakoff and Langacker. One needs an intermediate level that generalizes the specific findings and constitutes a neurodynamic model of semantic processing. Such a model will build on the topology of the brain, synchronization and desynchronization, coupling of subnetworks with self-organization (filtering, choice of dominant modes), self-reference and monitoring in consciousness, etc. The class of models emerging in this field will certainly belong to dynamic systems theory, although such qualitative and simple models as catastrophe theory will be insufficient, insofar as chaos-attractors, transitions between order and chaos, and stochastic models (with diffusion equations) will be needed. In order to use this type of

modelling for linguistic concerns, theoretical linguistics must be opened for dynamic models, which are more compatible with the future format of a neurolinguistically-founded semantics and are able to catch the intuitive notions of motion and force in natural language expressions.

BIBLIOGRAPHY

- Arnold V. I. 1986. *Catastrophe Theory*. Heidelberg: Springer.
- Ballmer, Thomas T. & Waltraud Brennenstuhl, 1986. *Deutsche Verben. Eine sprachanalytische Untersuchung des Deutschen Wortschatzes*. Tübingen: Narr.
- Bar-Hillel, Yehoshua. 1959. "On Syntactical Categories". *Journal of Symbolic Logic* 15: 1-16.
- Bloomfield, Leonard. 1926. "A Set of Postulates for Linguistic Analysis". *Language* 2: 153-164. Reprinted in: Hockett, Charles F. (ed.), 1970. *A Leonard Bloomfield Anthology*. Chicago, Ill.: Indiana University Press: 70-80.
- Chomsky, Noam. 1957. *Syntactic Structures*. Den Haag: Mouton.
- Engel, Andreas K. 2004. „Synchronisation und Wahrnehmungsbewusstsein“. Paper presented at the symposium: "Freier Wille – frommer Wunsch", Nürnberg, October 2004 (download from: www.40hz.net).
- Fauconnier, Gilles and Mark Turner. 2002. *The Way we Think. Conceptual Blending and the Mind's Hidden Complexities*. New York: Basic Books.
- Gazzaniga, Michael S., Richard B. Ivry & George R. Mangun. 1998. *Cognitive Neuroscience. The Biology of the Mind*. New York: Norton.
- Haken, Hermann. 1983. *Synergetics. An Introduction* (Third revised and augmented edition). Berlin: Springer.
- Haken, Hermann. 1996. *Principles of Brain Functioning. A Synergetic Approach to Brain Activity. Behavior and Cognition*. Berlin: Springer.
- Haken, Hermann & Michael Stadler, eds. 1990. *Synergetics of Cognition*. Proceedings of the International Symposium at Schloß Elmau. Berlin: Springer.
- Herrmann C.S., Munk M.H.J., Engel A.K. 2004. „Cognitive Functions of Gamma-band Activity: Memory Match and Utilization". *Trends in Cognitive Sciences* 8: 347-355.
- Husserl, Edmund. 1913/1970. *Ideen zu einer reinen Phänomenologie und phänomenologischen Philosophie*, vol. I: Allgemeine Einführung in die reine Phänomenologie. (new edition, 1950) Den Haag: Nijhoff.
- Johansson, Gunnar. 1976. "Spatio-temporal Differentiation and Integration in Visual Motion Perception". *Psychological Research* 38: 379-393.
- Johnson, Mark. 1990. *The body in the mind : the bodily basis of meaning, imagination, and reason*. Chicago: Univ. of Chicago Press.
- Kelso, J. A. Scott. 1995. *Dynamic Patterns. The Self-Organization of Brain and Behavior*. Cambridge (Mass.): Bradford.
- Lakoff, George and Mark Johnson. 1981. *Metaphors We Live By*. Chicago: University of Chicago Press.
- Lakoff, George. 1987. *Women, Fire, and Dangerous Things. What/How Categories Reveal About the Mind*. Chicago: Chicago U.P.
- Lakoff, George. 1993. *The Contemporary Theory of Metaphor*. *Orthony* 1993. 202-221.
- Langacker, Ronald. 1984. *The Nature of Grammatical Valence*. Series A; Paper 131. Trier: Linguistic Agency Trier.
- Langacker, Ronald. 1987. *Foundations of Cognitive Grammar*. Theoretical Prerequisites. Stanford: Stanford U.P.
- Langacker, Ronald. 1993. *Foundations of Cognitive Grammar*. Descriptive Application. Stanford: Stanford U.P.
- Langacker, Ronald. 1990. *Concept, Image and Symbol. The Cognitive Basis of Grammar*. Berlin: De Gruyter.
- Langacker, Ronald. 2006. On the Continuous Debate about Discreteness. *Cognitive*

- Linguistics* 17 (1): 107-151.
- Merleau-Ponty, Maurice. 1945/1999. *Phénoménologie de la perception*. Paris: Gallimard (reprinted 1999).
- Oullier, O., K.J. Jantzen, F.L. Steinberg & J.A.S. Kelso. 2004. „Neural Substrates of Real and Imagined Sensorimotor Coordination”. *Cerebral Cortex Advance Access* 24: 1-11.
- Orthonoy, Andrew, ed. 1993. *Metaphor and Thought* (Second Edition). Cambridge: Cambridge U.P.
- Peitgen, H.-O., H. Jürgens & D. Saupe. 1992. *Bausteine des Chaos. Faktale*. Heidelberg/Stuttgart: Springer/Klett.
- Petitot, Jean, 1985 : *Morphogenèse du sens I*, Paris : Presses Universitaires de France.
- Petitot, Jean. 1992. *Physique du Sens*. De la théorie des singularités aux structures sémi-narratives. Paris : Editions du CNRS.
- Petitot, Jean, 2003. *Morphogenesis of Meaning* (translated by Franson Manjali; a revisited version of Petitot 1985). Bern: Lang.
- Pike, Kenneth Lee. 1971. *Language in Relation to a Unified Theory of the Structure of Human Behavior* (2nd edition). The Hague: Mouton.
- Prigogine, Ilya. 1980. *From Being to Becoming- Time and Complexity in Physical Sciences*. San Francisco: Freeman.
- Stewart, Ian. 1990. *Does God Play Dice? The Mathematics of Chaos*. London: Penguin Books.
- Talmy, Leonard. 1975. „Semantics and Syntax of Motion”. *Syntax and Semantics* ed. by. John Kimball. vol. 4, 181-238. New York: Academic Press.
- Talmy, Leonard. 1976. „Semantic Causative Types”. *Syntax and Semantics* (The Grammar of Causative Constructions) ed. M. Slubutani, vol. 6. . 43-116. New York: Academic Press.
- Talmy, Leonard, 1983. „How Language Structures Space”. *Spatial Orientation: Theory, Research, and Application* ed. by Herbert Pick & Linda Acredolo. New York: Plenum Press. Reedited in : Talmy 2000a. 177-254.
- Talmy, Leonard. 1988. „Force Dynamics in Language and Cognition”. *Cognitive Science* 12 (1). Reedited in: Talmy, 2000a: 409-470
- Talmy, Leonard. 2000a. *Toward a cognitive semantics. Vol. 1: Concept structuring systems*. Cambridge (Mass.): MIT Press.
- Talmy, Leonard. 2000b. *Toward a cognitive semantics. Vol. 2. Typology and Process in Concept Structuring*. Cambridge (Mass.): MIT Press.
- Talmy, Leonard. 2007. *Cognitive Semantics. An Overview*, Pre-final draft of an article to appear in: *Handbook of Semantics* edited by Claudia Maienborn, Klaus von Heusinger, Paul Portner, Mouton de Gruyter (visited 10th of March 2008) <http://linguistics.buffalo.edu/people/faculty/talmy/talmyweb/Recent/overview.html>)
- Teisman, Anne. 1999. “Solutions to the Binding Problem. Progress Through Controversy and Convergence”. *Neuron* 24: 105-110.
- Thom, René. 1972. *Stabilité structurelle et morphogenèse*. Paris : Interéditions.
- Thom, René. 1983. *Mathematical Models of Morphogenesis*. Horwood (Wiley). New York.
- Thom, René. 1988. *Esquisse d'une sémiophysique. Physique aristotélicienne et théorie des catastrophes*. Paris: Interéditions.
- Tomasello, Michael, 2003. *Constructing a Language. A Usage-Based Theory of Language Acquisition*, Harvard U.P., Cambridge (Mass.).
- Whitney, William Dwight. 1899. *The Life and Growth of Language. An Outline of Linguistic Science*. New York: Appleton and Company (first publication 1875).

- Wiener, Norbert, 1948. *Cybernetics or Control and Communication in the Animal and the Machine*. New York: Wiley.
- Wildgen, Wolfgang. 1982. *Catastrophe Theoretic Semantics. An Elaboration and Application of René Thom's Theory*. Amsterdam: Benjamins.
- Wildgen, Wolfgang. 1985. *Archetypensemantik. Grundlagen einer dynamischen Semantik auf der Basis der Katastrophentheorie*. Tübingen: Narr.
- Wildgen, Wolfgang. 1987. "Dynamic Aspects of Nominal Composition". *Process Linguistics. Exploring the Processual Aspects of Language and Language Use, and the Methods of their Description* ed. by Thomas T. Ballmer & Wolfgang Wildgen, 128-162. Tübingen: Niemeyer.
- Wildgen, Wolfgang. 1988. "Processual Semantics of the Verb". *Journal of Semantics* 5: 321-344.
- Wildgen, Wolfgang. 1994. *Process, Image, and Meaning. A Realistic Model of the Meanings of Sentences and Narrative Texts*. Amsterdam: Benjamins.
- Wildgen, Wolfgang. 1998. "Chaos, Fractals and Dissipative Structures in Language or the End of Linguistic Structuralism" *Systems: New Paradigms for the Human Sciences* ed. by W. Koch & G. Altmann, 596-620. Berlin: de Gruyter.
- Wildgen, Wolfgang. 1999. *De la grammaire au discours. Une approche morphodynamique*. Bern : Lang.
- Wildgen, Wolfgang. 2004. *The Evolution of Human Languages. Scenarios, Principles, and Cultural Dynamics*. Amsterdam: Benjamins.
- Wildgen, Wolfgang. 2005. "Catastrophe Theoretical Models in Semantics". *Quantitative Linguistics/Quantitative Linguistik. Ein Internationales Handbuch* ed. by Reinhard Köhler, Gabriel Altmann & G. Pietrowski, 410-423. Berlin: de Gruyter.
- Wildgen, Wolfgang. 2006a. "The Dimensionality of Text and Picture and the Cross-cultural Organization of Semiotic Complexes". *Aspects of Automatic Text Analysis. Festschrift in Honor of Prof. Dr. B. Rieger* ed. by Reinhard Köhler & Alexander Mehler, 421-442. Berlin: Springer.
- Wildgen, Wolfgang. 2006b. „Kognitive Grammatik und neurokognitive Forschung“. *Theorien und Begriffe der Repräsentation. Beiträge zu einem Workshop* ed. by Hans Jörg Sandkühler, 115-134. Universitätsverlag: Universität Bremen.
- Wildgen, Wolfgang. 2008. *Kognitive Grammatik. Klassische Paradigmen und neue Perspektiven*. Berlin: Mouton de GRuyter.
- Wildgen, Wolfgang & Peter Plath. 2005. „Katastrophen- und Chaostheorie in der linguistischen Modellbildung“. *Quantitative Linguistics/Quantitative Linguistik. Ein Internationales Handbuch* ed. by Reinhard Köhler, Gabriel Altmann & G. Pietrowski, 688-705. Berlin: de Gruyter.
- Wright, George H. von. 1966. "The Logic of Action: A Sketch". *The Logic of Decision and Action* ed. by N. Rescher. Pittsburg: University of Pittsburg Press.
- Zeeman, E. C. 1977. *Catastrophe Theory: Selected Papers 1972-1977*. Cambridge (Mass.): Addison-Wesley.